

Competitors in all events must comply with the Regulations in this Section, and in addition with the Specific Regulations for the individual type of event.

1.1. Liabilities [5.1]. All persons connected with the event, whether by taking part in it or acting in an official capacity, shall be deemed to be bound by the General Regulations and the Supplementary Regulations, and must comply with the Law in relation to motor vehicles.

1.1.1. Any breach of these or other valid Regulations appertaining to the event shall, whether or not a penalty is specified, be subject to any or all of the penalties specified in these Regulations [O 2.1].

1.1.2. An Entrant shall bear the prime responsibility for the compliance with the Regulations by all persons connected with an entry. If an Entrant is not present at an event in person, his nominated driver, or if there is more than one driver, the first nominated driver, shall be deemed to be his agent and shall bear all the duties and responsibilities of the Entrant.

1.1.3. Any misdemeanour of a driver acting as an agent shall not absolve the Entrant from responsibility and both driver and Entrant shall be liable to penalty.

1.1.4. Any driver who is not acting as an Entrant's agent or any other person carried in or assisting with a competing car during an event shall not be absolved from his own responsibility under the relevant Regulations because of the responsibilities assumed by the Entrant or his agent.

1.1.5. Any person in possession of an official badge or other means of identification issued by the organiser shall be deemed to be assisting the Entrant to which the means of identification concerned has been issued.

1.2. These Regulations and any of the Appendices thereto may be amended or added to by means of announcements published in an official MSA Bulletin.

1.2.1. No interpretation or clarification of any Regulation will be valid unless in writing or in an official document and will only be valid during the current year [A 2.5.1].

2. REGISTRATION AND LICENSING OF COMPETITORS

2.1. Introduction

2.2. Competitor Registration

2.3. How to Apply for a Competition Licence

2.4. Name – Assumed

2.5. Address and Nationality

2.6. Acts Prejudicial to Motor Sport

2.7. Minimum Ages

2.8. Medical Declaration – All Applicants

2.9. Medical Declaration – Car, Truck or Kart Racing and all International Licence Applicants

2.10. Medical Declaration – International Licence Applicants – 45 and Over

2.11. Medical Declaration – Disabled Drivers

2.12. Competition Licence – Period and Validity

2.13. Competition Licence – Types

2.14. Competition Licence – Grades

2.15. Competition Licence – Retention, Downgrading and Upgrading of Licences

2.16. Competition Licence – Fees

2.17. Competition Licence – Inspection

2.18. Competition Licence – Restrictions

2.19. Competition Licence – Holder's Indemnity and Undertakings

2.20. Competition Licence – Waiver

2.21. Grade of Event and Licence Types and Grades

2.22. Entrants

2.23. Advertising

2.1. Introduction

The Motor Sports Association (MSA) has been empowered by the Federation Internationale De L'Automobile (FIA) to register and licence British citizens wishing to compete nationally under the MSA's Motor Sports Regulations and/or internationally under the FIA's International Sporting Code. Under certain circumstances citizens of other countries may also apply for registration. Registration will be effected by the issue of a Competition Licence of a type applicable to the motor sports discipline and the status, National or International, in which the applicant wishes to compete. Subject to certain conditions a status of licence may be upgraded at any time during the year. Registration shall expire at the end of the year shown on the Competition Licence. Any person from 8 years of age wishing to register must complete a Competition Licence application form. All applicants will be required to complete a medical self declaration. First time applicants 18 years and over applying for a Car, Truck or Kart Racing licence will be required to pass a medical examination and will be required to complete an annual medical self declaration until the age of 45 after which they will be required to pass an annual medical examination. Applicants for all International grades of Competition Licence will also be required to pass an annual medical examination. International licence applicants 45 years of age and over must include a stress related Electrocardiogram. All other applicants will be required to complete an annual medical self declaration. The following regulations contain all terms and conditions of registration and licence issue.

2.2. Competitor Registration

2.2.1. Registration will be effected by the issuing of a Competition Licence by the MSA. Such issue shall be conditional upon the applicant's credentials satisfying the MSA. At all times the MSA reserves the right to refuse to issue a Competition Licence. The reason(s) for any such refusal shall be stated.

2.2.2. Any Competition Licence issued will remain the property of the MSA which reserves the right to withdraw or suspend at any time. The reason(s) for any such withdrawal or suspension shall be stated.

2.2.3. A Competition Licence granted by the MSA does not constitute a certificate of the competency of the holder.

2.3. How to Apply for a Competition Licence

2.3.1. With the exception of first time applicants for a Race, Kart or Stage Rally licence, applicants should read these notes and complete an Application for Competition Licence Form provided by the MSA. Any changes to the wording on the official form will make it null and void. After having completed all the relevant sections of the application form, an applicant should send it, with the appropriate fee, to the MSA. The MSA will use its reasonable endeavours to process and deliver the licence to the applicant within 15 working days of receipt of the application by the MSA. Processing may take longer if we have to check the applicant's health. Therefore, you are recommended to allow for this time before the first event for which the licence is required. Applicants with no health or other problems appertaining to their application may obtain their licences within 3 working days on payment of an Express Handling Fee. To speed the process please clearly mark the envelope 'EXPRESS' and this should preferably be sent by Recorded Delivery. For applicants paying the additional Express Handling fee arrangements may be made, upon request, to confirm to organisers that they are a licence holder, this will usually include the waiver of the non-production of licence fine [2.17.1].

If an applicant doesn't receive the licence, after allowing for the processing and delivery time, the MSA should be notified in writing. If the notice is received by the MSA within 6 weeks of despatch of the licence by the MSA, it will issue a duplicate. After 6 weeks have elapsed, the normal duplicate licence charge will be levied in accordance with Section Z.

2.3.2. RACE – A competitor making an application for the first time for a Race licence must obtain a novice race driver 'Go Racing Driver Pack', which contains the required application form, from the MSA and then complete an approved course at a school registered with the Association of Racing

Drivers' School (ARDS). The procedure to be followed is contained in the 'Pack'.

Exemptions to 2.3.2 are as follows:

2.3.2.1. Anyone who has held a National 'B' Race licence at any time during 2001, 2002 or 2003. Competitors who have not renewed or held a National 'B' licence since 2000 or earlier must comply with 2.3.2.

2.3.2.2.* Anyone who can provide proof of having ever held, or entitled to hold, a Race licence of higher status than Restricted or National 'B'. Competitors who have not renewed their licence for 5 years or more will be required to pass the ARDS written examination.

2.3.2.3.* Anyone who has held a Competition Licence during 2002 or 2003 and can produce written proof of having been classified as a finisher in at least eight Rallycross events during that time and who passes a written examination.

2.3.2.4.* Anyone who is entitled to an International 'A' or 'B' Kart licence and who passes a written examination.

2.3.2.5.* Anyone who, being a foreign national, can produce proof from their ASN that they have the necessary racing experience.

*As the written examination is based on the Competitors' Yearbook and other information contained in the 'Go Racing Driver Pack', it is recommended that the pack is purchased in these exemption categories.

2.3.2.6. A National 'A' Race licence may be applied for by a holder of an International Competition Licence issued by the Auto Cycle Union and providing that proof is produced of competing in International motor cycle racing during the preceding five years, subject to passing the ARDS written examination, as referred to in 2.3.2 of this section.

2.3.3. KART – A competitor making an application for the first time for a Kart licence must obtain a novice kart driver 'Starting Karting Pack', which contains the required application form, from the MSA and then complete an approved course at a school registered with the Association of Racing Kart School (ARKS). The procedure to be followed is contained in the 'Pack'. Exemptions to 2.3.3 are as follows:

2.3.3.1. Anyone who has held a National 'B' Kart licence at any time during 2001, 2002 or 2003. Competitors who have not renewed or held a National 'B' licence since 2000 or earlier must comply with 2.3.2.

2.3.3.2.* Anyone who can provide proof of having ever held, or entitled to hold, a Kart or Race licence of higher status than Restricted or National 'B'. Competitors who have not renewed their licence for 5 years or more will be required to pass the ARKS written examination.

2.3.3.3. Anyone who can provide proof of having ever held a Kart Endurance licence and can produce written proof of having been classified as a finisher in at least 6 Kart Endurance races, held under the jurisdiction of the MSA, during 2002, 2003 or 2004.

2.3.3.4. Anyone who can provide proof of holding a National Schools Karting Association (NatSKA) National licence during 2002, 2003 or 2004.

2.3.3.5.* Anyone who can provide proof of holding a KRCB Pro-Racer card and has obtained eight signatures from qualifying races, a minimum of four of which must be outdoor races. (The 'Starting Karting Pack' is required in this instance and the driver will be required to pass the ARKS written examination.)

2.3.3.6. Anyone who, being a foreign national, can produce proof from their ASN that they have the necessary Karting experience.

*As the written examination is based on the Competitors' Yearbook and other information contained in the 'Starting Karting Pack', it is recommended that the pack is purchased in these exemption categories.

2.3.4. STAGE RALLY – A competitor making an application for the first time for a Stage Rally licence must obtain a novice stage rally 'Go Rallying Pack', which contains the required application form, from the MSA and then complete an approved course at a school registered with the British Association of Rally Schools (BARS).

The procedure to be followed is contained in the 'Pack'. Exemptions to 2.3.4. are as follows:

2.3.4.1. Anyone who has ever held a Non-Race National 'B' licence or higher, or equivalent, valid for driving on Special Stage Rallies held before 31 December 2001.

2.3.4.2. Anyone who has ever held a Restricted or National Rally licence.

2.3.4.3. Anyone who, being a foreign national, can produce proof from their ASN that they have held a licence valid for driving on Special Stage Rallies or Hill Rallies.

2.4. Name – Assumed

2.4.1. If registration and a licence is requested under an assumed name or a pseudonym, special application should be made at the time of applying for registration. The MSA may, if it thinks fit, issue a licence in such a name. Any assumed name must not be likely to deceive or offend. A person granted a licence in an assumed name shall not take part in any competition except under the name shown on such licence.

2.5. Address and Nationality

The MSA shall be entitled to register and issue licences to:

2.5.1. A British citizen, including a citizen of any part of the territory of the MSA.

2.5.2. A citizen of any other country represented on the FIA providing they can provide proof to their parent ASN that they are permanently resident within the UK and that their ASN has given its prior permission and has recovered any licence originally issued.

2.6. Acts Prejudicial to Motor Sport

2.6.1. A competition licence holder who does anything to bring motor sport into disrepute or commits an act prejudicial to the interest of motor sport generally may face disciplinary action [O 1.1.4].

2.7. Minimum Ages

2.7.1. In all cases where the applicant is under 18 years of age it is necessary that the application is guaranteed by the parent or legal guardian, proof of guardianship may be required.

2.7.2. Please refer to the table within this section to assess eligibility.

2.8. Medical Declaration – All Applicants

There are certain medical conditions as detailed in 2.9.6 below, which are incompatible with the practise of motor sports at any status of event. All applicants 18 years of age and over are required to complete an annual medical self declaration as to their medical fitness to compete in motor sports competition. If an applicant has not had a recent medical examination and eyesight test or they do not understand any part of the medical requirements set out hereunder they are strongly recommended to have an examination or eye test. At all times any decision as to fitness or unfitness to compete shall ultimately reside entirely with the MSA.

2.8.1. Doping Classes and Methods of the IOC Medical Commission

(see table opposite)

2.8.2. Access to Medical Reports Act 1988/Access to Personal Files and Medical Reports (Northern Ireland) Order 1991 ("the Acts")/Access to Health Records and Reports Act 1993 (Isle of Man).

Before we can apply for a medical report from a doctor who has cared for you, we need your consent by signing the Declaration in Section 5 of the application. Before doing so, however, you should read this notice carefully, as it sets out your rights under the Acts and the procedures for dealing with reports.

(a) You do not have to give your consent but, if you do, you can say whether you wish to see the report before it is sent to the MSA's Medical Consultant. If you do not give consent, we will be unable to proceed with your application for a Competition Licence.

(b) If you say you wish to see the report, we will write to your doctor and advise you that we

2.8.1. Doping Classes and Methods of the IOC Medical Commission

Duplicated below is the “Doping Classes and Methods of the International Olympic Committee Medical Commission” Card. Please contact the MSA’s Medical Section Administrator at Motor Sports House for any clarification required on any prescribed or ‘over the counter’ medication for use in Motor Sport.

THE FOLLOWING ARE EXAMPLES OF CLASSES AND METHODS PROHIBITED IN SPORT:	
Classes	<p>Stimulants eg. amphetamine, bromantan, caffeine (above 12 mcg/ml), carphedon, cocaine, ephedrine, certain beta: agonists*.</p> <p>Narcotics eg. diamorphine (heroin), morphine, methadone, pethidine.</p> <p>Anabolic Agents eg. methandienone, nandrolene, stanozolol, testosterone, clenbuterol, DHEA, androstenedione, 19-norandrostenediol, certain beta: agonists*.</p> <p>Diuretics eg. acetazolamide, frusemide, hydrochlorothiazide, triamterene, mannitol.</p> <p>Peptide Hormones, Mimetics & Analogues eg. growth hormone, corticotrophin, chorionic gonadotrophin, erythropoietin, insulin*, and all respective releasing factors and their analogues.</p>
Methods	<p>Blood Doping</p> <p>Pharmacological, Chemical & Physical Manipulation eg. substances and methods that alter the integrity and validity of the urine; eg. probenecid, catheterisation, sample substitution or tampering.</p>
Classes of drug subject to certain restrictions	<p>Alcohol & Cannabinoids Restricted in certain sports. Refer to regulations of national or international sports federations.</p> <p>Local Anaesthetics Route of administration restricted to local or intra-articular injection, when medically justified*.</p> <p>Corticosteroids Route of administration restricted to anal, aural, dermatological, inhalation, nasal and ophthalmological (but not rectal), local or intra-articular injection*.</p> <p>Beta-blockers Restricted in certain sports. Refer to regulations of national or international sports federations.</p>
	* Written notification of administration should be given to the relevant medical authority, eg. governing body medical officer. Check with your governing body.

TREATMENT GUIDELINES – Examples of permitted and prohibited substances		
	ALLOWED	BANNED
ASTHMA	sodium cromoglycate, theophylline, salbutamol*, terbutaline*, salmeterol*, beclomethasone**, fluticasone*, (**by inhalation only & written notification of administration should be given to relevant medical authority) (**by inhalation only).	products containing sympathomimetics eg. ephedrine, isoprenaline, fenoterol, rimiterol, orciprenaline.
COLD/ COUGH	all antibiotics, steam & menthol inhalations, permitted antihistamines, terfenadine, astemizole, pholcodine, guaiphenesin, dextromethorphan, paracetamol.	products containing sympathomimetics eg. ephedrine, pseudoephedrine, phenylpropanolamine.
DIARRHOEA	diphenoxylate, loperamide, products containing electrolytes (eg. Dioralyte, Rehidrat).	products containing opioids eg. morphine.
HAYFEVER	antihistamines, nasal sprays containing a corticosteroid or xylometazoline, eyedrops containing sodium cromoglycate.	products containing ephedrine, pseudoephedrine.
PAIN	aspirin, codeine, dihydrocodeine, ibuprofen, paracetamol, all non-steroidal anti-inflammatories, dextropropoxyphene.	products containing opioids, caffeine.
VOMITING	domperidone, metoclopramide.	

Warning: Medications prescribed by your doctor may contain prohibited substances. Some vitamin, herbal and nutritional substances may contain prohibited substances, such as Guarana, Ma Huang, Chinese Ephedra. The substances listed above are only examples of substances permitted or prohibited by the IOC. Not all sports adopt the IOC Medical Code.

USE OF THESE PRODUCTS IS AT YOUR OWN RISK.

have done so, and we will tell your doctor you wish to see the report. You will then have 21 days to contact the doctor about arrangements for you to see the report. Of course, the quicker you act, the quicker your application for a Competition Licence can be considered.

(c) If you say you do not wish to see the report, we do not have to notify you if we apply for one. However, if before such a report is sent to us, you write to the doctor saying you wish to see it, you will then have 21 days to contact the doctor about arrangements for you to see the report.

(d) Whether or not you say you wish to see the report before it is sent to us, the doctor must let you see a copy for up to six months after it is supplied, if you ask.

(e) If you ask the doctor for a copy of the report, he can charge you a reasonable fee to cover his costs.

(f) If you see a report before it is sent to us, the doctor cannot submit it until he has your consent. You can write to the doctor, asking him to amend any part of the report which you consider to be incorrect or misleading, and have attached to the report a statement of your views on any part where you and the doctor are not in agreement.

(g) The doctor is not obliged to let you see any part of a report if, in his opinion, that would be likely to cause serious harm to your physical or mental health or that of others, or would indicate the doctor's intentions towards you, or if disclosure would be likely to reveal information relating to, or the identity of someone else who has supplied information about you, unless that person has consented or the information relates to, or has been supplied by, a health professional involved in caring for you. In such cases, the doctor must notify you and you will be limited to seeing any remaining part of the report. If it is the whole report, which is affected, he must not send it to us unless you give your consent.

2.9. Medical Declaration – Car, Truck or Kart Racing and all International Licence Applicants

2.9.1. An applicant 18 years of age or over applying for a Car, Truck or Kart Racing Competition Licence must pass a Medical Examination by their General Practitioner (GP) before applying for their first licence following their 18th birthday. Thereafter they will be required to complete an annual medical self declaration until the age of 45. Applicants 45 years of age and over must undergo and pass an annual medical examination. The Competition Licence must be issued within 6 months of the date of the medical after which time the report will need to be revalidated by the examining GP. For International licence requirements for those 45 years and over, refer to section 2.10.

2.9.2. All applicants for an International Competition Licence must pass a Medical Examination by their GP every year. International Competition Licences incorporate a FIA Medical Certificate of Aptitude.

2.9.3. No Car, Truck, Kart Racing or International licence will be issued until the Medical Examination Report, if required, has been completed, endorsed and signed by the applicant's GP.

2.9.4. In the event of any uncertainty as to whether or not the patient satisfies the Medical requirements, the examination form should be signed by the GP and should then be sent directly to the MSA's Medical Section Administrator, with any additional information which may be of assistance.

2.9.5. Any fee charged for the medical examination is the responsibility of the applicant. This also applies to any additional reports and Specialist examinations requested by the MSA in connection with an application for a Competition Licence.

2.9.6. The medical examination should be carried out to a standard similar to that required for Life Insurance, but with specific attention to the following:

2.9.6.1. Diabetics requiring treatment with insulin will not normally be issued with a licence valid for Racing, Karting, Rallycross, Stage Rallying or International Rallying. Note, for an International Rally licence, no distinction is drawn between Driver and the Navigator, both occupants of the car being required by the FIA to hold a full International Rally Driver's licence. In certain circumstances the Medical Consultant at the MSA will be prepared to consider applications in writing by Insulin controlled Diabetics. Each applicant would need to present themselves to a Diabetics Specialist recommended by the MSA and any costs incurred would be borne by the applicant.

2.9.6.2. Epilepsy is incompatible with fitness to Race, Kart, Rallycross or Stage Rally. If a person with epilepsy has not had a fit or medication to prevent or control fits for a period of ten years they may present that case to the MSA's Medical Consultant for consideration. For other events a person with epilepsy may be considered for a competition licence providing they can show that they have not had a fit for five years whether on or off medication.

2.9.6.3. The following medical conditions may prevent the granting of a Competition Licence:

- (a) Myocardial infarction.
- (b) Myocardial ischaemia.
- (c) Coronary artery by-pass surgery.
- (d) Coronary Angioplasty.
- (e) Valvular Disease of the Heart or other abnormal condition whether operated on or not.
- (f) Severe hypertension which has given rise to cardiopulmonary problems.

<i>Discipline</i>	<i>Driver</i>	<i>Navi- gator</i>	<i>Front Passenger</i>	<i>Rear Passenger</i>	<i>Remarks</i>
RACE					
Car Race	16				14 'T' cars only
Truck Race	21				21 min age on road
Kart Race L/C	16				210cc max to 17
Kart Race S/C	8				85cc gearbox from 13
RALLY					
Road Rally	17+RTA	12		2	2-4 in a Child Seat
Navigation Rally	17+RTA	12		2	2-4 in a Child Seat
Stage Rally	17+RTA	16			
TRIALS					
Production Trial	15		12		
Standard Trial	15				
Classic Reliability Trial	17+RTA		14	2	2-4 in a Child Seat
Sporting Trial	16		16		
AUTOTEST					
Autotest	16				
PC Autotest	14		12		1400cc saloons to 16
OFF-ROAD					
Hill Rally	17	16			
Safari	17	16			
Off-Road Tyro	13		12	2	2-4 in a Child Seat
Off-Road Trial	17		14		Junior Trials from 8-17
SPEED					
Sprint & Hillclimb	16				
Minicross	14				
Autocross	16				
Clubcross	14				
Rallycross	16				
Drag Race	16				Junior dragsters from 8

2.9.6.4. The following eyesight standards are required to be met:

- (a) Minimum corrected visual acuity must be 6/6 with both eyes open.
- (b) Minimum binocular field should measure at least 120 degrees along the horizontal meridian with no defects within the central 20 degrees.
- (c) Spectacles should be fitted with shatterproof lenses. Contact lenses if worn should be of the 'soft' variety.
- (d) A person who suddenly loses sight in one eye will not be allowed to hold a licence until five years has lapsed.
- (e) Double vision is not compatible with the issue of a Competition Licence.
- (f) Drivers must have normal colour vision in that they can distinguish the primary colours of red and green.

2.9.6.5. General

- (a) It is strongly recommended that all competitors should be immunised against tetanus.
- (b) It is recommended that asthmatics should wear an identity tag (i.e. bracelet or necklace) declaring that they are asthmatic and that they should inform the event's Chief Medical Officer of their condition before competing.
- (c) It is strongly recommended that an annual eyesight test is taken.
- (d) The mouth should be kept clear of anything likely to cause a blockage of the airway in the event of an incident. It is advisable to remove false dentures and to refrain from chewing gum.
- (e) Competitors are advised to refrain from wearing jewellery which, in the event of an incident, could prove hazardous.

2.10. Medical Declaration – International Licence Applicants – 45 and Over

In addition to the requirements of 2.8 and 2.9 above, the following are required for International Licence Applicants 45 years of age and over.

2.10.1. A current written report of a stress related Electrocardiogram is required for all International licence applicants 45 years of age and over. A stress related ECG will be valid for two years and will need to be subsequently undertaken in respect of the licence application in the third year. (Do not send Trace).

2.10.2. The stress electrocardiogram shall be carried out to a symptom limitation on a motorised treadmill to a standard Bruce Protocol; an equivalent bicycle ergometric protocol is acceptable. Recording is to be made in 12 leads, at rest, following hyperventilation, and for each minute of exercise and each of ten minutes of recovery. Reason for cessation to be stated; report to be by a Specialist accredited in cardiology.

2.11. Medical Declaration – Disabled Drivers

Any applicant with a congenital abnormality of any limb, or amputation or with any other disability should first contact the MSA's Medical Section Administrator at Motor Sports House who will be pleased to advise and help the applicant.

In addition to the requirements of 2.8, 2.9 and 2.10 above, disabled applicants should note the following:

2.11.1. The following medical conditions may prevent the granting of a Competition Licence:

- (a) Paraplegia
- (b) Hemiplegia
- (c) Quadriplegia
- (d) Loss of limb.

2.11.2. When applying for a Competition Licence all applicants are required to declare any physical disability.

2.11.3. Disabled drivers may be required to present themselves for examination by the MSA's Medical Consultant. If required to attend such examination the applicant will be required to provide, in advance, a note from his/her GP describing the applicant's disability and, if applicable, an opinion from any specialist who has been consulted.

2.11.4. Any driver or co-driver/navigator who has any medical condition or disability or who is currently on anti-coagulant therapy should declare this at the time of entering. Such information to be solely for the use of the Chief of medical services in the event of an accident.

Those competing in accordance with 2.11.2 should carry a white 'D' on a blue background, which will be issued by the MSA on the instructions of the MSA's Medical Consultant, on the door closest to the disabled occupant, or adjacent to the side numbers of a single-seater, to alert marshals in the case of an incident.

2.12. Competition Licence – Period and Validity

2.12.1. Unless otherwise rendered invalid, all licences, for the purposes of acquaintance and submission to these rules, run from the 1st January to the end of the calendar year shown on the licence.

2.12.2. To be valid, a Competition Licence must be signed in ink and must bear a passport type photograph of the holder, which must be permanently fixed to the licence in the space provided (except for an entrant's licence issued in the name of a firm or organisation).

2.13. Competition Licence – Types

The types of licence available are Race, Kart, Speed, Drag, Stage Rally, Off Road, Non-Race & Entrant.

2.14. Competition Licence – Grades

The grade of licences available are (highest first) International, National 'A', National 'B' and Clubman.

2.15. Competition Licence

Retention and Downgrading

An applicant may retain his or her licence if they meet the criteria set out below. If an applicant for whatever reason does not qualify to retain their current licence grade they will be automatically downgraded according to these regulations. Upon renewal an applicant may voluntarily take out a licence of lesser grade than that to which they are entitled. Upon receipt of a written request, an existing licence holder who wishes to exchange their licence for one of lesser grade may do so but only once during the year. The charge for so doing will be the payment of the downgrade fee as per Section Z and forfeit of the cost difference (if any) between the two licences. Any subsequent upgrade will be charged in accordance with Section Z.

Upgrading Procedure

If you want to upgrade your licence on renewal and you have met the Upgrading criteria detailed in this section, please forward your completed 2004 Competition Licence Application Form together with the appropriate licences containing the signatures and the required payment to the Licence Section.

If you want to upgrade your licence and you are already in possession of a current 2004 Competition Licence, please detach and complete the white upgrade/addition card contained in the Competitors' Year Book and forward it, together with your 2004 Competition Licence and any other appropriate licences containing the necessary signatures with the required payment to the Licence Section. The payment is calculated as the difference between the cost of the existing licence and the new licence plus the upgrading fee as detailed in Section Z. A request for an upgrading signature has to be made to the organisers, and if the results of the event show that the driver's performance was satisfactory, his/her Competition Licence will be signed by the Clerk of the Course in the space provided. In the case of Kart Races, only the MSA Steward of the Meeting is empowered to sign and only one signature per meeting, per class is permitted. A maximum of two signatures may be obtained at a car race meeting. In exceptional circumstances only, documentary evidence, such as printed official results sheets may be accepted as proof of performance for upgrading.

2.15.1. RACING – How to Retain a Licence

Note: A competitor who is unable to retain their Race licence as mentioned below may be required to pass a course at an Association of Racing Drivers' School. Exemptions to this requirement are as detailed in 2.3.2. of this section. Competitors qualified to retain a

National 'A' or higher licence, who have not renewed their licence for 5 years or more will be required to pass the ARDS written examination. (a) A competitor who held a National 'B' Race licence in any one of the years 2001, 2002 or 2003 may renew it for a 2004 National 'B' Race licence.

(b) A competitor who can provide proof of having ever held a National or National 'A' Race licence may renew it for either a 2004 National 'A' Race, International Historic Race or National 'B' Race licence.

(c) A competitor who can provide proof of ever having held an International Historic Race licence may renew it for a 2004 International Historic Race licence or a 2004 National 'B' Race licence.

(d) A competitor who can provide proof of ever having held an International 'C' Race licence may renew it for a 2004 International 'C' Race licence or a 2004 National 'A' Race, International Historic Race or National 'B' Race licence.

(e) A competitor who can provide proof of ever having held an International 'A' or 'B' Race licence may renew it for a 2004 International 'C' Race, National 'A' Race, International Historic Race or National 'B' Race licence. Special arrangements exist for retaining an International 'A' or 'B' licence and are contained in Appendix L of the FIA International Sporting Code.

2.15.2. RACING – How to Upgrade a Licence

Please note that Rallycross signatures are NOT acceptable for upgrading any Race licence.

(a) National 'B' to National 'A' Race

A competitor who is qualified to hold a 2004 National 'B' Race licence may upgrade it to National 'A' Race licence either at renewal or during the year as follows:

Obtain Clerk of the Course's signatures on the reverse of licence(s) certifying that the qualifying events have been successfully completed. These are 6 National 'B' or Clubman Races (these can all be from one circuit), and must not contain more than 1 signature from Races organised by or on behalf of Racing Schools which form part of a school course or curriculum. One of the Clerk of the Course signatures required for having successfully completed a Race may be replaced by a Clerk of the Course signature for completing a day on a marshal's post during a race meeting. One of the Clerk of the Course signatures for having successfully completed a Race may be replaced with a signature for having successfully completed an ARDS Advanced Course.

(b) National 'A' to International 'C' Race

A competitor who is qualified to hold a 2004 National 'A' Race licence may upgrade it to International 'C' Race licence either at renewal or during the year as follows:

Obtain Clerk of the Course's signatures on the reverse of licence(s) certifying that the qualifying events have been successfully completed. These are 3 National 'A' Races OR 2 National 'A' plus 2 National 'B' or Clubman Races OR 6 National 'B' or Clubman Races. In all options signatures must be obtained at 3 different venues.

(c) International 'C' to International 'B' Race

A competitor who is qualified to hold a 2004 International 'C' Race licence may upgrade it to International 'B' Race licence either at renewal or during the year in accordance with Appendix L of the FIA International Sporting Code.

(d) International 'B' to International 'A' Race

In accordance with Appendix L of the FIA International Sporting Code.

(e) National 'B' to International Historic Race

A competitor who is qualified to hold a 2004 National 'B' Race licence may upgrade it to International Historic Race licence either at renewal or during the year as follows:

Obtain Clerk of the Course's signature on the reverse of licence(s) certifying that 5 races for Historic cars built before 1971, have been successfully completed.

All International Race licences are valid for International Historic Races.

(f) International Historic to National 'A' Race

A competitor who is qualified to hold a 2004 International Historic Race licence may add a National 'A' Race licence either at renewal or during the year as follows:

Comply with (a) taking the possession of the International Historic Race licence as 5 credit signatures towards the total.

(g) How to add an International Historic to a National 'A' Race

Competitors who hold a National 'A' Race licence may add an International Historic Race licence either at renewal or during the currency of the National 'A' Race licence. Fees will be as per Section Z.

(h) Karting to National 'A' Race

Kart competitors who hold an International 'A' or International 'B' Race licence, will receive 1 credit towards a National 'A' Race licence.

2.15.3. RALLYING – How to Retain a Licence

Note: A competitor who is unable to retain their Stage Rally licence as detailed below may be required to pass a course at a British Association of Rally Schools (BARS). Exemptions to this requirement are detailed in 2.3.4. of this Section.

(a) A competitor who can provide proof of having ever held a National or National 'A' Rally licence may renew it for a 2004 National 'A' Stage Rally licence or a 2004 International Historic Rally licence.

(b) A competitor who can provide proof of having ever held an International Rally licence may renew it for a 2004 International Rally licence or a 2004 International Historic Rally licence.

(c) A competitor who can provide proof of having ever held an International Historic Rally licence may renew it for a 2004 International Historic Rally licence or a National 'A' Stage Rally licence.

2.15.4. RALLYING – How to Upgrade a Licence

Please note that neither Rallycross or Off Road signatures are NOT acceptable for upgrading any Stage Rally licence.

(a) Rally National 'B' Stage to Rally National 'A' Stage

A competitor who is qualified to hold a 2004 National 'B' Stage Rally licence may upgrade it to a National 'A' Stage Rally licence either at renewal or during the year by obtaining Clerk of the Course signatures on the reverse of licence(s) certifying that four Special Stage Rally events have been completed.

(b) Rally National 'B' Stage to Rally International Historic

A competitor who is qualified to hold a 2004 National 'B' Stage Rally licence may upgrade it to an International Historic Rally licence either at renewal or during the year by obtaining Clerk of the Course signatures on the reverse of licence(s) certifying that four Special Stage Rally events have been completed.

(c) Rally National 'A' Stage to Rally International

A competitor who is qualified to hold a 2004 National 'A' Stage Rally licence may upgrade it to an International Rally licence either at renewal or during the year by obtaining Clerk of the Course signatures on the reverse of licence(s) certifying that 1 National 'A' Special Stage Rally or 2 National 'B' Special Stage Rally events have been completed.

(d) Non-Race National 'B' or equivalent to Rally National 'B' Stage and above

Follow the procedure for applicants for a Stage Rally licence detailed in 2.3.4. and then proceed as in (a) and (c) above.

(e) Rally National 'A' Navigator to Rally International

Follow the procedure for applicants for a Stage Rally licence detailed in 2.3.4. and then proceed as in (a) and (c) above.

(f) Adding a Rally National 'A' Navigator

Competitors may add a National 'A' Navigator licence to a Non-Race National 'B', Clubmans or Rally National 'B' Stage licence at time of renewal or during the year on payment of the fee as detailed in Section Z.

2.15.5. SPEED – How to Retain a Licence

(a) A competitor who has ever held an International, National or National 'A' Speed licence may renew it for the same or lower grade of licence or a Speed National 'A' (OPEN) in 2004.

(b) All other applicants can apply for a Non-Race National 'B'.

2.15.6. SPEED – How to Upgrade a Licence

(a) Non-Race National 'B' to Speed National 'A'

Either Obtain Clerk of the Course's signatures at four Clubman or National 'B' Race, Hillclimbs or Sprints. (One of the four signatures required may be replaced by a signature from an MSA Recognised Hillclimb and Sprint School confirming completion of the school course) OR Obtain the Clerk of the Course's signatures at six Clubman or National 'B' Rallycross events.

(b) Speed National 'A' to Speed National 'A' (OPEN) or Speed International

A competitor who can provide proof of having held a National 'A' Speed licence prior to 31.12.2002 may upgrade it to a Speed National 'A' (OPEN) or International Speed licence on payment of the appropriate fee as detailed in Section Z, OR obtain Clerk of the Course's signatures at four Clubman, National 'B' or National 'A' Race, Hillclimbs or Sprints OR obtain the Clerk of the Course's signatures at two Clubman, National 'B' or National 'A' Rallycross events.

Non-Race National 'B' to National 'A' Drag to International Drag

(c) To obtain a licence for Drag Racing higher than National 'B', a driver must submit with their application to upgrade, a letter of endorsement from a recognised Drag Racing Club. A system of licence endorsement for the category of vehicle being driven is in place. See Section L.

2.15.7. RALLYCROSS – How to Retain a licence

(a) A competitor who can provide proof of ever having held a National or National 'A' Rallycross licence may renew it for the same or lower grade of Stage Rally or Speed licence in 2004.

(b) A competitor who can provide proof of having ever held an International Rallycross licence may renew it for the same or lower grade of Stage Rally licence or Speed licence in 2004.

(c) All other applicants can apply for a Non-Race National 'B'.

2.15.8. RALLYCROSS – How to Upgrade a Licence**(a) Non-Race National 'B' to Speed National 'A'**

Obtain the Clerk of the Course's signatures at six Clubman or National 'B' Rallycrosses or as detailed in 2.15.6.(a).

(b) National 'A' to International Speed

A competitor who holds or has held a National 'A' Rallycross, National 'A' Rally, National 'A' Stage Rally or National 'A' Race licence prior to 31.12.2002 may upgrade it to an International Speed licence on payment of the appropriate fee as detailed in Section Z, OR obtain the Clerk of the Course's signatures at two Clubman, National 'B' or National 'A' Rallycross events or as detailed in 2.15.6.(b).

2.15.9. TRUCK RACING – How to Retain a Licence

Retention of a Truck Racing licence is exactly the same as for a Race licence. Please read Section 2.15.1.

2.15.10. TRUCK RACING – How to Upgrade a Licence

These are special licences and the National Truck Racing licence can be issued in one of the two following ways:

(a) A competitor who is qualified to hold a National 'A' or International Race licence must satisfactorily complete an agreed instruction course in driving Heavy Goods Vehicles.

OR

(b) A competitor who already is the holder of a category C RTA driving licence must complete an ARDS racing course and take out a National Truck Race licence.

(c) National Truck to International Truck

Obtain the Clerk of the Course's signature at four races of at least 8 laps duration. A maximum of 2 signatures can be obtained at one meeting. If races are of less than 8 laps, 2 such races will count for one signature.

2.15.11. KART– How to Retain a Licence

Note: A competitor who is unable to retain their Kart licence as detailed below may be required to pass a course at an Association of Registered Kart Schools (ARKS). Exemptions to this requirement are detailed in 2.3.3. of this Section. Competitors qualified to retain a National 'A' or higher licence, who have not renewed their licence for 5 years or more will be required to pass the ARKS written examination.

(a) A competitor who held a National 'B' Kart licence during 2001, 2002 or 2003 may renew it in 2004.

(b) A competitor who has ever held a National or National 'A' Kart licence may renew it for the same or lower grade of licence in 2004.

(c) A competitor who has ever held an International 'C' Kart licence may renew it for the same or lower grade of licence in 2004.

(d) Special arrangements exist for retaining an International 'A' or 'B' licence and are contained in the CIK-FIA Annuaire.

2.15.12. KART – How to Upgrade a Licence

(a) National 'B' to National 'A' Kart

Obtain the MSA Steward's signature on the reverse of the licence at six Clubman or National 'B' Kart Races (these can all be from one circuit). A competitor may only obtain one signature per meeting per class. Completion of the ARKS Course [2.3.3] will constitute one of the six signatures.

(b) National 'A' to International 'C' Kart Junior or Senior

A competitor must be eligible for a National 'A' licence in order to apply for an International 'C' licence. An International 'C' Junior licence can be issued to drivers between the dates of their 13th birthday and their 15th birthday. An International 'C' Senior licence can be issued to drivers on or after their 15th birthday. Application must be made in accordance with the Regulations published in the 2004 CIK Annuaire.

(c) National 'A' or International 'C' to International 'B' Kart

A competitor must be over 15 years of age to be eligible for an International 'B' licence and make application in accordance with 2004 CIK Annuaire.

(d) International 'B' to International 'A' Kart

A competitor must be over 15 years of age and application must be made in accordance with the Regulations published in the 2004 CIK Annuaire.

2.15.13. OFF-ROAD – How to Retain a Licence

(a) Any competitor who has ever held a Rally National, Rally National 'A' or Rally International licence may apply for the Off-Road National 'A' licence in 2004.

(b) Any competitor who has ever held a Rally International licence may apply for the Off-Road International licence in 2004.

(c) All other competitors may apply for the Non-Race Clubman or Non-Race National 'B' licence without qualification.

2.15.14. OFF-ROAD – How to Upgrade a Licence

(a) Non-Race National 'B' or Non-Race Clubman to Off-Road National 'A'

A competitor who is qualified to hold a 2004 Non-Race National 'B' or Non-Race Clubman licence may upgrade it to a National 'A' Off-Road licence either at renewal or during the year by obtaining Clerk of the Course signatures on the reverse of licence(s) certifying that four Competitive Safaris have been completed.

(b) Off-Road National 'A' to Off-Road International

A competitor who is qualified to hold a 2004 National 'A' Off-Road licence may upgrade it to an International Off-Road licence either at renewal or during the year by obtaining Clerk of the Course signatures on the reverse of licence(s) certifying two National 'B' Competitive Safaris or one National 'A' Competitive Safari have been completed.

2.16. Competition Licence – Fees

See Section Z for details.

2.17. Competition Licence – Inspection

2.17.1. Licences must be produced for inspection at all events prior to a competitor taking part. Competitors failing to produce a correct licence will be fined as detailed in Section Z and may be excluded from the event by the Stewards. Under no circumstances can this fine be considered as a substitute for not holding a valid Competition Licence.

2.17.2. Only the originals of licences are acceptable. Photocopies or facsimiled copies are not acceptable.

2.17.3. One Entrant's licence covers all the entries at a meeting in the name of that Entrant.

2.18. Competition Licence Restrictions

2.18.1. No person shall apply for or hold a current Entrant's and/or Driver's licence from more than one ASN [other than in 2.18.4] and such licences shall, if both are required, always be obtained from the same ASN.

2.18.2. No person may apply for or hold more than one current licence of the same category.

2.18.3. In special circumstances and, only once annually, the holder of a licence issued by the MSA may apply to another ASN to issue them with a licence. This may only be granted if they are permanently resident in the territory of the ASN to whom they are applying, have surrendered their licence to, and obtained written permission from the MSA.

2.18.4. A British citizen, having a licence issued in a foreign country which is not endorsed with the EU flag [see 2.21.4.], will be able to take part in events within the territory of the MSA, subject to also taking out an MSA National 'B' or 'A' Competition Licence.

2.19. Competition Licence – Holder's Indemnity and Undertakings

In consideration of MSA granting a Competition Licence, the holder binds himself to the following requirements and undertakings [A 5 and B 9.4.]:

(a) To abide by the MSA Regulations and any amendments or additions thereto which may be in force at any time that the licence is used for the purpose of taking part in a motor competition.

2004 CHART OF MINIMUM ACCEPTABLE LICENCES

MOTOR SPORT DISCIPLINE	EVENT STATUS (as defined in Supplementary Regulations)			
	CLUBMAN	NATIONAL 'B'	NATIONAL 'A'	INT'L
AUTOTESTS *	Clubman	Clubman	Any National 'B'	
ALL TRIALS* (excluding 4x4)	Clubman	Clubman	Any National 'B'	
NAVIGATION RALLY*	Clubman	Any National 'B'	Any National 'A'	
ROAD RALLY* (including Historic)	Clubman	Any National 'B'	Any National 'A'	
SAFARIS, HILL RALLIES, TIME TRIALS, TEAM RECOVERIES	Clubman	Clubman	Off-Road or Stage Rally National 'A' (5)	Off-Road or Stage Rally International
CLUBCROSS	Clubman			
AUTOCROSS (including MINICROSS)	Any National 'B'	Any National 'B'		
HILL CLIMBS, SPRINTS, SAND RACES	Any National 'B' (8)	Any National 'B' (8)	Speed or Race National 'A' (8)	Speed or Race International
DRAG RACES		Any National 'B'	Drag National 'A'	Drag International
RALLYCROSS	Any National 'B'	Any National 'B'	Stage Rally Nat 'A' Race Nat 'A' Speed Nat 'A'	Rally Int'l Race Int'l Speed Int'l
STAGE RALLIES	Stage Rally National 'B' (6)	Stage Rally National 'B' (6)	Stage Rally National 'A' (7)	Rally International
STAGE RALLIES (HISTORIC)	Stage Rally National 'B'	Stage Rally National 'B'	Stage Rally Nat 'A' or Rally Int'l Historic	Rally International or Rally Int'l Historic
RACE	Race National 'B'	Race National 'B'	Race National 'A'	Race Int'l
RACE HISTORIC	Race National 'B'	Race National 'B'	Race National 'A' or Race Int'l Historic	Race Int'l or Race Int'l Historic
RACE KART	Kart National 'B' or Race National 'B'	Kart National 'B' or Race National 'B'	Kart National 'A'	Kart Int'l
RACE TRUCK	Race National Truck	Race National Truck	Race National Truck	International Truck
NB				
(1) A higher grade licence is always valid for lower permit events of the same discipline.				
(2) Race licences are valid for speed events.				
(3) Race, Speed and Stage Rally licences are valid for Rallycross.				
(4) * When these events are organised solely for bona-fide members of the organising club, no licence other than a club membership card is required.				
(5) Club membership card valid for Navigator [H 16.3.2].				
(6) Any National 'B' and Rally National 'A' Navigator are valid for Stage Navigator.				
(7) Rally National 'A' Navigator is valid for Stage Navigator.				
(8) Speed National 'A' (Open) or Race National 'A' required for vehicles defined in L 7.1.5 of the Regulations.				

(b) To pay as liquidated damages for any breach of these Regulations any sums awarded against him or the organisation which he represents within the maxima set out in the Regulations.

(c) To acknowledge that all persons having any connection with the promotion and/or organisation and/or conduct of the event are insured against loss or injury caused through their negligence.

(d) That to the best of the licence holder's knowledge and belief the driver(s) possess(es) the standard of competence necessary for an event of the type to which an entry relates and that the vehicle entered is suitable and road worthy for the event having regard to the course and the speeds which will be reached.

(e) That where appropriate, the use of the car entered shall be covered by insurance as required by the law, which is valid for such part of the event as shall take place on roads as defined by the law.

(f) That any competitor taking part in an event is suffering from any disability whether permanent, or temporary, which is likely to affect prejudicially his normal control of his vehicle at the time of the event, may not take part unless he has declared such disability to the MSA which has, following such declaration given its written consent to the competitor to compete.

(g) That any application form for a licence which is signed by a person under the age of 18 years shall be countersigned by that person's Parent or Legal Guardian.

(h) Competitors should abstain from the consumption of alcohol or drugs before or during a competition.

2.19.1. The Parent/Legal Guardian/Guarantor of a minor shall sign the following declaration: "I am the Parent/Legal Guardian/Guarantor (Delete as appropriate) of the above and I understand that I or my Guarantor shall have the right to be present during any procedure being carried out under the General Regulations of the MSA".

2.20. Competition Licence – Waiver for Clubsport Events

The MSA waives the requirement for Competition Licences for some types of club motor sport [see B. 3 and B. 4 for details].

2.20.1. The MSA also waives the requirement to hold a Competition Licence for competitors who hold a National licence issued by the National Schools Karting Association (NatSKA) in accordance with their rules which have been agreed with the MSA.

2.21. Grades of Event and Licence Types and Grades

2.21.1. Competitors need a Competition Licence for most forms of motor sport

organised under a permit issued by the MSA. Select the status and type of event from the table opposite; this shows the minimum acceptable licence.

2.21.2. Competitors must normally have registered and have their licence before competing in any event, but with the specific exception of Race, Kart Races and Stage Rallies organisers are permitted to accept a properly completed Non-Race National 'B' or Non-Race Clubman Application Form along with the appropriate fee in lieu of the licence. This can, however, only be done at events of National 'B' or lower status. No priority fee is payable and the fine for non-production of licence is not applicable.

2.21.3. Licences issued by Motorsport Ireland will be deemed valid for all British events providing the holders comply with all the requirements for the event. Under a reciprocal agreement British licences are valid in Eire.

2.21.4. National Competition Licences issued by countries outside the UK will be deemed valid for British events, providing either of the following applies:

(a) the event has been inscribed on the 2004 International Sporting Calendar and that the holders comply with all the requirements for the event.

OR

(b) a Professional competitor in possession of a valid licence (which features the EU flag) and medical, issued by the ASN of a member country of the European Union and has provided such proof to their issuing ASN.

The holder will be subject to MSA Regulations whilst competing in that event. To ensure compatibility with our licence requirements, clubs should require foreign competitors to comply with the following:

(a) If the event is of National 'B' or Clubman status, the competitor must be a member of, or join, the organising club or one of the invited clubs.

(b) At a National 'B' Race meeting, the competitor must sign a declaration that he/she is competent to compete in the appropriate Race, and must satisfy the Clerk of the Course prior to practice that he/she is aware of the flag signals. The competitor should be subject to special observation during practice, and must achieve a lap time of at least 120% of the class best, unless the Clerk of the Course is satisfied as to extenuating circumstances. If he/she has not previously finished six Races, the competitor must carry a novice cross on the rear of the car [J 12.3].

(c) At a National 'A' Race meeting, the competitor must sign a declaration that he/she is competent to compete in that status of Race, and must satisfy the Clerk of the Course prior to practice that he/she is aware of the

flag signals. The competitor should be subject to special observation during practice, and must achieve a lap time of at least 120% of the class best, unless the Clerk of the Course is aware of extenuating circumstances.

(d) At any International Race meeting the competitor must hold a valid International licence.

(e) Short Circuit Kart Racing. The competitor must carry 'Novice' number plates unless he/she can provide the organisers with proof of having finished in at least six Kart Races. Normal observation during practice.

(f) Long Circuit Kart Races. A declaration must be signed that the competitor has finished at least six Kart Races (long or short circuit). The competitor must carry 'Novice' number plates unless proof can be provided to the organisers of having finished at least four long circuit Kart Races. Special observation during practice.

(g) National 'B' Rallies. The driver must hold a road licence valid within the UK. No other restrictions [see (k) regarding insurance].

(h) National 'A' Rallies. As (g) above, but the competitor must sign a declaration that he/she has competed in at least four rallies.

(i) Co-Drivers. No special requirements.

(j) Vehicle Log Books must be issued. This can be done at scrutineering, but competitors must be warned to bring the appropriate photographs.

(k) RTA Insurance can be arranged subject to an acceptable proposal form being submitted. Note. The laid down time scale must be rigidly observed.

(l) All other events. For all other events which do not utilise the public highway, no special restrictions apply.

2.21.5. British licence holders of National 'A' or above grade will be entitled to compete in events within the EU and the Comparable Countries [2.21.4] providing the event has been inscribed on the 2004 International Sporting Calendar and comply with the requirements of the event. They will then be subject to the regulations of the appropriate ASN.

2.21.6. British licence holders of any International grade will be entitled to take part in events of the appropriate type on condition that those events are entered on the FIA International Calendar. MSA International licences incorporate automatic permission to take part in such events and contain the words 'valid as a visa, Article 70 ISC'. In case of difficulty please contact the MSA.

2.21.7. Concessions to holders of an International Historic licence may be available, please refer to the FIA International Sporting Code.

2.21.8. Non UK Race licence holders attending an MSA recognised competition driving school

may take part in up to two national events organised by that school on the strict condition that they have the agreement of both their parent ASN and the MSA. In such cases their original licence must be lodged with the MSA who will then issue a suitable licence for the event, following receipt of a completed application. This licence will be exchanged for their original licence at the conclusion of the event(s).

2.21.9. British licence holders of National 'A' or above grade may request, at time of application, to have their Competition Licence endorsed Professional and feature the EU flag. These endorsements will permit the holder to participate in national events within the EU and the Comparable Countries, where that event has been inscribed on the hosting ASN's National Calendar. They will then be subject to the regulations of the appropriate ASN.

To enable consideration of this endorsement the applicant must supply official confirmation, from a professionally qualified accountant, that they have declared to the British fiscal authority monies earned through their participation, as a competitor, in motor sport, during the preceding financial year.

2.22. Entrants

All personal licences entitle the holder to enter the car, truck or kart in which he/she will personally take part in the event. Any other organisation, company, sponsor or person must obtain an ENTRANT'S LICENCE by making separate application by completing an Application for Competition Licence Form.

The entrant is the legal entity who is responsible for all acts and/or omissions of the driver/co-driver and any person connected with the entry. A competitor must ensure that any entrant is aware of this.

The maximum number of words permitted in an Entrant's title is six. Only one Entrant's licence may be used in connection with an entry (i.e. two three word licences cannot be used to make one entry).

An International Entrant's licence is valid for all events both inside and outside the UK.

A National Entrant's licence is valid for all events inside the UK excluding International, except in the case of events for Karts and Historic Cars, where it has the same validity as an International Entrant's licence. Competitors who intend to use this licence internationally must advise the MSA at the time of application.

2.22.1. Where a competitor has not reached his 18th birthday the Entry for an event must be supported by Parent or Legal Guardian as Guarantor. Such Guarantor will be considered as being the Minors' Entrant, and as such will be subject to these Regulations.

2.22.2. The Guarantor, or his representative, must attend the event with the Minor, and sign-on as his Entrant. When a Guarantor's representative attends an event and signs-on as his Entrant, the Representative must produce the Guarantor's written and signed authorisation to so act.

2.23. Advertising

During the period of validity of an event Permit there are no restrictions on advertising on vehicles in the UK except as follows:

- The display must not be offensive.
- No display should interfere with the easy identification of the vehicle's competition number.
- No display on a transparent surface can exceed 5in (13cm) in depth.
- Advertising is prohibited on road rallies except as provided for in K 22.5.4 and K 22.20.2.
- Tobacco related advertising is prohibited on all competing vehicles, their support vehicles and any other form of equipment directly connected with an entrant or competitor. As an exception to this any car which can be proved by way of its history, through its chassis number via the FIA or MSA Historic Vehicle Identity Form (HVIF), to have run in a particular livery will be allowed to continue to display that livery in the same colours and original size of logos.

2.24. Event Advertising

2.24.1. The competitor must make available to the organiser a specified area of 645 sq cm on each side of the car, adjacent to the space allocated for the vehicle's competition number, and clearly visible, on which the organiser may specify the event, its sponsor or the course on which it is being run. Normally, this will be above or below the number background.

2.24.2. The competitor taking part in an event of a championship series must also make available a specified area of 645 sq cm on each side of the car on which the organiser may specify the championship and its sponsor (if that sponsor is different from the sponsor of the individual event) so long as the competitor is required to display only the title of the championship. Failure to display the appropriate sticker may result in loss of Championship points.

*3. ENTRIES

Individual entries for an event must be made in writing on an appropriate entry form [B 9.3 and B 9.4] before the specified closing date of entries.

3.1. Acceptance of entries shall be at the discretion of the organisers, whether or not the number of entries submitted exceeds the

maximum number to be accepted in the competition [B 10.1]. The organisers may at their discretion:

3.1.1. Select entries as they wish.

3.1.2. Refuse any entry. No event or championship organiser shall have the right to refuse an entry on unreasonable grounds and competitors may appeal to the MSC if they feel the grounds are unreasonable.

3.1.3. Refund any entry fee or excuse a competitor payment of any entry fee.

***3.1.4.** Publicise in the SRs the method by which entries are to be selected.

***3.1.5.** Furthermore, the organisers may require accepted entries to comply with some specific conditions prior to being permitted to start, *but only provided such a condition is stated in the SRs.*

***3.1.6.** Abandon, cancel or postpone the competition or any class therein should insufficient entries be received, *provided that a minimum number of entries is specified in the SRs.*

3.1.7. Amalgamate existing classes or create additional classes should the type and size of entry appear to warrant such action, provided that the intention so to act is notified in writing to all competitors affected, not later than the closing date for entries.

3.1.8. Permit the nomination of drivers to be delayed up to the time of issuing the official list of competitors.

3.2. The organisers shall, within seven days of receipt of an entry, or within two days of the closing date for entries, whichever is the earlier, notify an entrant that his entry is:

3.2.1. Accepted, or

3.2.2. Refused, or

3.2.3. Placed on a list of reserves and the position on that list, or

3.2.4. Held in abeyance for further consideration.

3.2.5. Furthermore, in the case of an entrant notified that his entry is classified under 3.2.4, he shall be notified within two days of the closing date of entries as to the final classification of his entry.

3.2.6. An entrant shall be free to withdraw an entry to which 3.1.7, 3.2.3 or 3.2.4 relates provided the organisers are so informed in writing within three days of the entrant being notified.

3.2.7. When an organiser is accepting entries up to one hour before a competition [as permitted by B 10.3], he must notify all accepted entries, not less than three days before the event, if there is any likelihood of the event being cancelled because of lack of entries.

3.3. Refund of Entry Fees. An entrant shall have the right of a refund of the entry fee only if:

3.3.1. The event is cancelled, or postponed for more than 12 hours, unless the SRs have provided for a specified part to be retained towards administrative expenses.

3.3.2. An otherwise eligible reserve entry is not permitted to take part in the event.

3.3.3. An entry is withdrawn as provided by 3.2.6.

3.3.4. An entry is refused.

3.3.5. Provision is made in the SRs for full or partial refund to a competitor notifying the organisers IN WRITING prior to a specified date, that he wishes to withdraw his entry.

4.1. ENTRANT'S RESPONSIBILITIES [1.1, 2.23]

An entrant shall ensure that:

4.1.1. Only the nominated car is used throughout the event.

4.1.2. Only the nominated driver(s) drive that car.

4.1.3. Only nominated persons are carried in that car.

4.1.4. An entrant shall, before the event, satisfy himself as to the eligibility and safety of the vehicle and the competence of its driver.

4.1.5. An entrant shall furthermore ensure that a vehicle is maintained in an eligible and safe condition throughout the event or meeting.

4.1.6. The act of presenting a vehicle for official scrutiny shall be deemed a declaration of its fitness and eligibility for the event and an acceptance of the consequences of such a declaration not being valid.

4.1.7. Vehicles shall comply with the MSA Technical Regulations and any appropriate Approved Formulae Regulations.

4.1.8. There shall be no requirement for eligibility of a vehicle additional to 4.1.7 *unless such requirement is stated in the SRs.*

4.1.9. The entrant shall be responsible for all acts or omissions on the part of his driver(s), mechanics, passengers, and all other persons assisting in any capacity in connection with his entry, but each of these shall also be responsible for any infraction of the Regulations.

4.1.10. Notwithstanding the above, the driver of any vehicle excluded as a result of the actions of his Entrant, Mechanic, engine or body builder, or any other person assisting in any capacity with his entry, may also be subject to any penalties associated with that exclusion.

4.2. Entrants and Drivers Forbidden to Abandon one Event and compete in another.

Any entrant having entered, or any driver having undertaken to drive in any event, who does not take part in that event and takes part in another event on the same day may thereby become liable to the penalty set out in Section Z. Provided also that a competitor who has been notified that his entry has been accepted conditionally or that a decision has

been deferred may enter for another event on the same day on condition that if his entry for the second event is accepted he shall forthwith notify the first organising club.

5.1. COMPETITOR'S RESPONSIBILITIES

5.1.1. All Entrants, Drivers, Navigators and other passengers must 'sign-on' on a form prescribed by the MSA and undertake to comply with the declarations laid down in B 9.4 and shall not be allowed to take part in the event until they have produced the necessary documents to prove their eligibility for the event, whether this be by means of an approved Club Membership Card and/or an MSA Competition Licence [or Licence application form completed as in 2.21.2]. In addition to the foregoing if the vehicle is to be used on the Public Highway an appropriate current valid Road Traffic Act Licence will also be required.

5.1.2. Competitors must present their vehicle, in a clean condition, with any relevant paperwork, for scrutineering at the nominated time prior to taking part in the event.

5.1.3. Competitors must attend any meeting or briefing where this is required by the SRs, by the Clerk of the Course, or by the Stewards of the Meeting.

5.1.4. Competitors and their service/pit assistants must at all times obey the instructions of an authorised official of the meeting.

5.1.5. Competitors and their service/pit assistants must at all times display means of identification (i.e. passes etc.) as provided by the organisers.

5.1.6. Competitors must remain available at an event until any protest period relating to their event has elapsed, failing which, any judicial action against or relating to that competitor may be heard in their absence.

5.1.7. Any competitor knowingly injuring a marshal, an official or spectator during an event must:

- (a) Ensure that adequate help is available.
- (b) Report the incident to a Senior Official as soon as possible.
- (c) Report personally to the Clerk of the Course, not later than the conclusion of the event, and remain at his disposal until released.
- (d) If the incident happened on the Public Highway, competitors are reminded of their obligations under the RTA.

5.1.8. A driver must at all times drive in a manner compatible with general safety and any penalty incurred under these regulations shall not prevent any appropriate action under O 1.1.5 or 1.1.6 in respect of careless or reckless driving or dangerous driving.

FOREIGN EVENTS

6.1. A competition licence holder proposing to compete in an event outside the European Union is required by FIA Rules to ensure that the event is inscribed on the FIA International Calendar. International Competition Licences issued by the MSA constitute an authorisation 'Visa' and allow eligible holders to compete abroad on such events. [See E 2.21.6.]

RESULTS AND AWARDS

7.1. Only competitors classified as finishers and who have produced the appropriate documents to prove their eligibility for a competition will be eligible for an award or an individual position in the results *unless the SRs specify otherwise*.

7.1.1. Any award which is not specifically offered to a person other than the entrant will be given to the entrant.

7.1.2. Where eligibility for an award depends upon club membership this will be determined by means of the club membership claimed on the entry form. Details of the club must be printed in the programme. No competitor may compete for more than one such award.

7.1.3. No competitor may be a member of more than one team competing for the same award *unless the SRs specify otherwise*.

7.1.4. A 'novice' will be a driver who has not previously won an award in a competition of similar or higher status and type *unless the SRs specify other conditions*.

7.1.5. The results of a competition will be 'Provisional' until all vehicles subject to Post-Event Scrutiny have been examined and a report submitted to the Clerk of the Course, every competitor has had an opportunity to protest and/or appeal in accordance with the Regulations, and such protest or appeal has been duly heard.

7.1.6. If no valid protest or appeal is received within the time limits specified in O 5.2, the results shall become Final and may not be changed subject only to the powers held by the MSA [A 3.3].

7.1.7. If the Provisional Results are amended for any reason, fresh Provisional Results must be published and these become subject to protest or appeal in accordance with 7.1.6.

7.1.8. If printed results sheets are available to all competitors on the day, copies of these results need not be posted to entrants. Any alteration to the Provisional Results must be notified to all entrants.

7.2. Advertisement of Results of Competition. Any competitor or other persons or body advertising the results of a competition shall state the exact conditions of the performance referred to, the nature of the competition, the category, class, etc., of the vehicle, and the

position and result obtained, and such additional information as the MSA may require. The publication of an advertisement, relating to the results of a competition drawn up in a way calculated to mislead the public, or the infringement of this Rule whether by way of omission from or addition to the particulars required to be stated or otherwise, shall render the person or body by whose authority or on whose behalf the advertisement is published or issued liable to the penalties provided by these Rules, and may entail the infliction of a penalty on the person responsible for drawing up the advertisement.

8. INSURANCE [B 17]

8.1. In respect of any event or part of an event held anywhere other than on a publicly adopted road, under a Permit issued by the MSA, competitors will be insured in respect of third party legal liability by the MSA Master Policy.

8.1.1. Competitors are not insured under this policy in respect of legal liability to other competitors. It is the competitor's responsibility to ensure that he is properly insured, as required by the Law, whilst on publicly adopted roads. Further details of Insurance are given in Section W.

8.2. The competitor shall comply with the terms of the master insurance policies effected by the MSA, the principle terms of which are summarised in Section W.

A full copy of the master insurance policy may be seen on application to the MSA Company Secretary at Motor Sports House.

9. PROCEDURE FOR CONTROL OF DRUGS AND ALCOHOL [B 20]

9.1.1. Any form of doping is strictly forbidden.

9.1.2. Doping is defined as:-

1) The use by, or distribution to a competitor of substances contained within Section 1 of the International Olympic Committee Medical Code Prohibited Classes of Substances and Prohibited Methods for the time being in force and/or

2) The use or adoption by a competitor of any of the procedures contained within Section II of the said Code and/or

3) The use or consumption by a competitor of such drugs or substances as are contained within Section III of the said Code, namely:-

- (a) Alcohol
- (b) Cannabinoids
- (c) Local anaesthetics
- (d) Corticosteroids
- (e) Beta Blockers

save that the use of local anaesthetics is permitted if approved by the Chief Medical Officer on the day of the event and the use of Corticosteroids and/or Beta Blockers is permitted if properly prescribed to the competitor for medical reasons by the

competitor's medical adviser. In this regard, however, the onus is upon the competitor to satisfy the Chief Medical Officer that such Corticosteroids and Beta Blockers have been so prescribed. The decision of the Chief Medical Officer in this respect shall be final.

9.1.3. Anti-doping controls at motor sporting events may be carried out for any of the substances, procedures or methods referred to in 9.1.2 in respect of which testing shall be by urine test save for alcohol which should be tested by alcometer [B 12.1.13].

9.1.4. A competitor must submit to an anti-doping control test if so instructed by the Clerk of the Course or by an official designated by the MSA for that purpose. Failure to do so will be taken as if a positive result had been obtained and dealt with accordingly.

9.1.5. Initiation is signified by the handing to the competitor of a Testing Notification Form. Refusal to accept the form will constitute refusal to take the test. Notwithstanding any other provision contained within these General Regulations any competitor selected for testing and having received a Testing Notification Form must remain at the event until he is notified either that the testing procedure has been completed or that he may leave [B 12.1.13].

9.1.6. Sampling may be initiated at any time from 'signing on' until, at the latest, thirty minutes after the competitor has concluded his part of the competition.

9.1.7. Competitors for testing may be selected at random by the Stewards of the Meeting or may include particular competitors as decided by the Stewards.

9.1.8. A positive sample will be reported to the Clerk of the Course and unless there are mitigating circumstances the competitor will be excluded from the event and reported to the MSA.

9.1.9. Any person assisting or inciting others in the contravention of doping regulations will be considered as contravening these regulations and may be subject to disciplinary action.

9.1.10. Procedure for Control of Drugs and Alcohol

Tests to ascertain the presence of drugs or alcohol may be carried out:-

- 1) By a Medical Officer under the authority of the Clerk of the Course or,
- 2) By an Anti-Doping Control Official appointed by the MSA who must sign-on and report to the MSA Steward on arrival at an event and arrange in conjunction with the Clerk of the Course and the Stewards for the selection to be made.

9.1.11. The following conditions must be fulfilled:-

- (a) The presence of the Medical Officer.
- (b) The presence of an Official of the Meeting appointed by the MSA Steward.

(c) The respect of confidentiality.

(d) The respect of the basic rights of the driver undergoing the test to have assistance from a third party of his/her choosing who is at the site at the time of testing.

(e) The possibility of counter-analysis.

(f) Justifications of a therapeutic nature must be taken into account.

9.1.12. Procedure for taking samples

9.1.12.1. Procedure for testing with Lion Alcometer.

The selection of competitors is signified by means of a Testing Notification Form. A sampling system check must be carried out before the competitor has provided a breath sample. The competitor will be given a choice of the individually wrapped mouthpieces. First the instrument should be checked to ensure it is ready to receive the sample. The sampling officer should depress the read button and hold fully down for at least 10 seconds. The display should be shown to the competitor and any attendants present. If the display shows 005 or greater during this 10 second ready check then a further ready check should be carried out after a period of two minutes. The sampling system should now be set, the selected mouthpiece should be attached to the sampling port on the top of the unit. The competitor will be offered the lipped end of the mouthpiece to blow through and the competitor will be told to fill his lungs and blow strongly enough to bring on light A and keep blowing at that pressure for long enough to bring on light B. He should continue to blow until told to stop, that is until the sample has been taken by pressing the read button. Failure to bring on both sampling lights could be regarded as failure to provide a suitable sample for breath analysis, in which case it may be possible to provide up to two further opportunities before a failure is recorded. During the sample-giving the sampling officer should hold the instrument; once the giving of the sample is complete the display can then be read after 30 seconds. This reading should be shown to the competitor and to any attendants and the competitor should then be asked to record it on the control test form.

9.1.12.2. Procedure for taking urine samples.

Proper surveillance must be present at all times but every effort must be made to maintain the privacy and dignity of the individual. At mixed events it is obviously imperative that supervisory personnel of both sexes are present.

(a) The time of arrival of the competitor at the Control Station must be noted. The time at which the sample itself is taken must also be noted.

(b) Only one competitor at a time should be allowed into the working room.

- (c) The competitor must be clearly identified.
- (d) The competitor must be informed as to how the sample is taken and the minimum quantity of urine (100ml) required.
- (e) The competitor must be allowed a free choice of one set (i.e. two containers) from the suitably labelled collecting vessels provided.
- (f) A nominated official must accompany the competitor to the room where the sample is to be given.
- (g) The urine sample must be divided into two containers. One container will be used for the first analysis and the second container kept as a reserve sample should a second analysis be required.
- (h) The containers should be sealed and the seal numbers recorded.
- (i) The competitor should be asked whether he has taken any drugs or medication within the last three days. Care should be taken to ensure that the competitor understands what a drug is, i.e. any substance introduced into the body which is not a food.
- (j) The necessary forms must be completed carefully. When the whole procedure has been completed correctly a signature should be obtained from the competitor confirming that he is satisfied with the procedure.
- (k) The samples must be delivered to the Analytical Laboratory as soon as possible after collection. If any delay seems likely the samples must be placed in a refrigerator or preferably be deep frozen.

9.1.12.3. Urine sampling analysis and notification of results. Analysis is carried out in accordance with IOC protocols. The standard turn-round for results is 28 days. Results are notified in confidence direct to the MSA and to the Sports Council. Where the laboratory issues a negative report, no action will be taken beyond informing the competitor.

9.1.12.4. In the cases where the Centre reports a positive finding, the MSA will immediately inform the individual concerned of the substance detected and of his right to insist that the reserve sample be analysed. The individual concerned has the right to be present or to be represented at the analysis of the second sample which should normally be within seven days of notification, and must not be ordered later than 28 days after the notification, failing which the result of the first sample alone will be considered.

9.1.12.5. Where the analysis of the sample shows the presence of the named, banned substance, or there is a refusal to submit to a test the MSA will initiate disciplinary proceedings.

10. MISCELLANEOUS

10.1. Successful Prosecution [B 12.1.14]
Any competitor who is successfully prosecuted as a result of his conduct in connection with a

motor vehicle whilst taking part in an event may, at the discretion of the Stewards of the Meeting, subsequently be excluded from the results of that event and be required to forfeit or return any award. Details of any successful prosecution known to the organising club shall be passed to the MSA, who will endorse his licence and may exclude the person concerned from competing in other events.

11. VEHICLES

11.1. Vehicles competing in events will conform to the Technical Regulations as appropriate.

11.2. Categories of Vehicles. Where the Supplementary Regulations leave any doubt as to the category in which a particular type of vehicle falls for the purposes of the competition, the position shall be governed by the definitions set out in these Regulations.

11.3. Scrutineering [C 6, C 8]

11.3.1. Before taking part in any competition, or practice for any competition, all vehicles must be presented to the event Scrutineers for examination and approval.

11.3.2. Log Books. Vehicle log books are required for certain sporting disciplines, as detailed in the Specific Regulations. Log books are available from International, National 'A' or National 'B' Scrutineers. Vehicle inspections can be arranged by appointment with an appropriate local scrutineer. By reciprocal arrangement the MSA will recognise log books issued by the RIAC (Royal Irish Auto Club). Such log books are considered valid for competitions within the UK.

To obtain a log book, a registration document (where appropriate) of the vehicle, or vehicle identity number is required. A recent colour print photograph (not Polaroid) must be affixed to the log book. Single seat racing cars must be shown side elevation, whilst saloon cars must show a driver's side front three quarter view with the number plate legible.

Log book continuation sheets may be obtained from the MSA.

Log books refer to complete cars, and may not be transferred with a bodyshell.

11.3.3. Vehicle log books must be sent to the MSA Technical Dept for any of the following reasons:

Issue of new log book. Change of engine type or capacity. Change of ownership. Change of bodyshell. Change of address. Vehicle disposal or dismantling. Change of vehicle colour (with new photo).

11.3.4. The fact of obtaining a Scrutineer's approval at pre-event scrutiny does not indicate that the Scrutineer is accepting any responsibility for the safety or the road-worthiness of the vehicle, nor does it indicate that the vehicle complies in all respects with the Regulations. Please note that pre-event

scrutineering or logbook inspection by a scrutineer is only a spot check of a limited number of key safety and eligibility features of a vehicle's condition. Alone it will not guarantee that the vehicle meets all applicable regulations or standards.

11.3.5. Subsequent to pre-event scrutiny, any vehicle involved in an accident, or having been modified in any way, must be represented to the Scrutineers for further examination.

11.3.6. At any time during an event, the Clerk of the Course, or the Scrutineers may order that a vehicle be re-examined, even if this involves stopping a vehicle whilst practising or competing.

11.3.7. At the conclusion of a competition, a number of vehicles, as agreed by the Clerk of the Course and the Scrutineers, or as ordered by the Stewards, or as laid down in the Regulations, may be required to be presented for Post-Event Scrutiny. No work may be done on such vehicles after finishing the competition except by permission or request of the Scrutineers, until after the examination is completed and the vehicle released. It is the responsibility of the competitor to provide appropriate tools and personnel within an agreed time to carry out the work required.

11.3.8. The Post-Event Scrutiny will be mainly directed at the vehicle's eligibility and may involve parts of the vehicle being sealed for subsequent stripping and examination [O 5.3.1]. This should normally be within a maximum of 30 days, although it can be extended by mutual agreement to 50 days. At the end of the season, series or championship, it should never exceed 30 days.

11.3.9. Vehicles, or components, may be sealed on the instructions of the Clerk of the Course, Stewards of the Meeting, the Technical Commissioners, or following a protest. Sealing may be by wire seals, special reactive paint, or other suitable method. Such seals must not be broken except with the written permission of the person who originally affixed the seal, or of the MSA, or by the person designated to examine the parts in question. The Technical Commissioner or Scrutineer examining the vehicle or component will report his findings to the Clerk of the Course for his action [O 3.1.2].

11.3.10. Approval of a vehicle will only be in relation to those items of the vehicle which have been examined and will only apply to the event which the vehicle has just completed.

11.3.11. Competition Numbers. Numbers must be displayed in a durable manner and be black, of a minimum size of 23cm high with stroke width of a minimum of 3.8cm on a white oblong background measuring not less than 48cm x 33cm which must extend at least 5cm beyond the outline of the numbers. If on a

white vehicle the background must be delineated at 48cm x 33cm by a continuous black line, except for cars of period A to E.

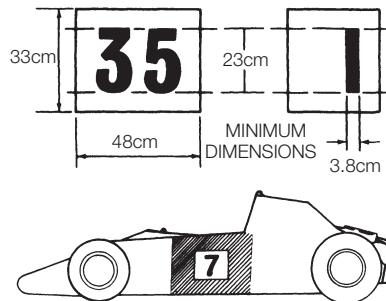

Numbers must be displayed on each side of the vehicle (front doors, alongside the cockpit or on rear wing end plates) and on the foremost part of the nose. Certain types of competition have special requirements which will appear in SRs (Subject to approval by the MSA) [See N 14.16 for Kart Numbers].

Note. Consideration should be given at all times to the positive identification of vehicles by the competition organisers, whose decisions will be final. The numbers must be of the 'Classic' type as shown below: 1-2-3-4-5-6-7-8-9-0.

In International events the name(s) of the driver(s) and the national flag of the country must be displayed on the front wings or body work.

Any means of identifying individual cars during a competition MUST be removed at the finish of the event.

TECHNICAL

12. The following technical regulations are mandatory and apply to vehicles in all forms of competition (other than karting). In addition vehicles must comply with the appropriate Specific Technical Regulations. Where there are several regulations concerning any particular subject it shall be taken, as a general principle, that one does not override another unless specifically stated.

12.1. As a general principle in all Technical Regulations, it is prohibited to carry out any tuning or modification that is not specifically permitted. The fact that some modifications are mentioned as prohibited does not imply that others are allowed.

All vehicles must:

12.2. Chassis/Body (including aerodynamics)

12.2.1. Be fitted with bodywork including a driver (and passenger) compartment isolated from the engine, wet batteries, gearbox,

hydraulic reservoirs, transmission shafts, brakes, road wheels, their operating linkages and attachments, petrol/fuel tanks, oil tanks, water header tanks and catch tanks.

Where a radiator is not isolated from the driver/passenger compartment a suitable deflector to be fitted to prevent fluid directly coming into contact with the vehicle's occupants.

12.2.2. With the exception of rear engine single seater racing cars or cars of periods A to D have a bonnet or casing of metal or solid flame resistant material covering and surrounding the main engine structure.

12.2.3. Have a protective bulkhead of non-inflammable material between the engine and the driver/passenger compartment capable of preventing the passage of fluid or flame. Gaps must be sealed with GRP or with putty that completely closes any gap at all times. Magnesium is prohibited for bulkheads.

12.2.4. Have a complete floor of adequate strength rigidly supported within the driver/passenger compartment.

12.2.5. Not have the space normally occupied by passengers encroached upon, but may have the passenger seats removed.

12.2.6. With the exception of cars of periods A to D have bodywork providing a minimum transverse cockpit opening width of 81cm. This width may not be interrupted.

12.2.7. With the exception of racing cars or cars of periods A to D be equipped on all wheels with mudguards which present no sharp edges and cover the complete wheel (flange+rims+tyre) around an arc of 120 degrees. This minimum coverage must:

(i) be achieved with a continuous surface of rigid material uninterrupted by any gaps, holes, slots or vents.

(ii) extend forward ahead of the axle line.

(iii) extend downward behind the wheel to not more than 7.5cm. above the axle line.

12.2.8. Aerofoils or spoilers may only be fitted to single seat racing cars (unless prohibited by an Approved Formula), or where specifically permitted, where FIA homologated, or where complying with National type approval.

12.2.9. If originally fitted with driver/ passenger doors, hatchback doors, sliding doors, opening boots or tailgates, these must be secured in the closed position during events.

12.2.10. Have effective means of ventilating closed cars.

12.2.11. Tinted glass in any window which can significantly affect through vision (in or out) or distort the colours of signal flags or lights, is prohibited.

12.2.12 With the exception of Off-Road Vehicles, Racing Trucks and Karts, in all vehicles with the driver seated normally, the soles of his/her feet, resting on the pedals in

the inoperative position, shall not be situated to the fore of the vertical plane passing through the centre line of the front wheels. Not applicable to vehicles constructed prior to 1.1.99 or for those vehicle designs which have participated in an MSA Permit Championship prior to 1.1.99.

12.3 Seating

12.3.1. Have a normal adequate seat for the driver. The seat must be rigidly located within the compartment and must not tilt, hinge or fold unless it is a production seat fitted with a serviceable locking mechanism preventing independent operation. It must support and retain the driver within the vehicle. The seat cushion (i.e. the part on which the occupant sits) when uncompressed, must not be less than 15.25cm below the top edge of the adjacent body side or door. Any other seats fitted must similarly comply and all seats must face forward. Cars of periods A to D are exempt from this requirement.

12.3.2. If a single seater, the maximum time for a driver to get in or out of the vehicle should not exceed 5 seconds.

12.4. Engines

12.4.1. If forced induction is used, the coefficient will be 1.7:1 *unless stated otherwise in Specific Technical Regulations or SRs.*

12.4.2. Be equipped with a positive method of throttle closing by means of external spring/springs so that in the event of failure of any part of the throttle linkage the throttle(s) are sprung closed.

Vehicles fitted with electronic throttle control as standard original manufacturer's equipment for that vehicle are exempt from this requirement.

12.5. Suspension

12.5.1. Be fitted with sprung suspension between the wheels and the chassis. Suspension must be controlled to avoid fouling of wheels on chassis or bodywork. Cars of periods A and B need not have sprung suspension, if originally built without it.

12.6. Brakes

12.6.1. Be fitted with brakes that are operative and capable of stopping the vehicle as required. Carbon disc brakes are prohibited unless specifically authorised by the MSA for a class or category of car.

12.7. Steering

12.7.1. Have a steering wheel with a continuous rim not incorporating any reflex angles in its basic shape (except for Drag Race vehicles). Wheels with flat rim segments i.e. 'D' shape wheels are permitted. Specifically not permitted are wheels having a non-continuous rim shape similar to that shown in the diagram below. Cars of periods A and B may have a tiller or alternative to a steering wheel if it formed part of the original vehicle.



12.7.2. Have steering movement controlled to avoid fouling of wheels on chassis or bodywork.

12.7.3. Rear wheel or four wheel steering is prohibited unless fitted on a Production vehicle by the manufacturer, or permitted under the Specific Technical Regulations, or SRs.

12.8. Wheels

12.8.1. Have not less than four road wheels and tyres (excluding the spare).

12.8.2. Not be fitted with any wheel spacer exceeding 2.5cm in thickness or of less than hub diameter. Multiple or Laminated Spacers are prohibited.

12.8.3. Have all hub nave plates and wheel embellishers removed.

12.9. Tyres

12.9.1. Have tyres complying with Specific Technical Regulations and/or Construction and

Use Regulations (if Standard Road Tyres), for the duration of the event.

12.9.2. Tyres, if treaded, must have not less than 1.6mm of tread remaining at the start of an event. Formula Ford 1600 1mm.

12.9.3. Where freedom of choice of tyres is left to the Competitor, the responsibility rests with each Competitor to ensure that the tyres to be used are of adequate rating having regard to the potential speed of their vehicle and the nature of the event.

12.9.4. The fitment and/or use of pressure control valves to wheels and/or tyres is not permitted.

12.10. Cooling

12.10.1. Have any fluid carrying lines or tubes carrying coolants through the driver/passenger compartment painted red, and if non-metallic to be internally or externally metal braided hydraulic pressure hose.

12.11. Transmission

12.11.1. Have the transmission outside the driver/passenger compartment, beneath the floor or secured in casings or coverings of solid material.

12.11.2. Be equipped with a reverse gear in normal working order unless otherwise stated in Specific Technical Regulations. Racing Cars of periods A to E are exempt from this requirement.

ABC

AUTOSPORT BEARINGS & COMPONENTS

SHOP ONLINE NOW!

Unit 3, Shepperton Business Park, Govett Avenue, Shepperton,
Middlesex TW17 8AB

Tel: +44(0)1932 225777 Fax: +44(0)1932 222215

E-mail: msadir@autosport-bearings.co.uk Website: www.autosport-bearings.co.uk

Contact: Graham Kemp or Lee Sinclair

The UK's leading motorsport distributors for Aurora, Fluro, IKO, INA, LDK, NMB, National, Natchi, Rose, Timken and Springfix bearings, Unbrako Bolts, NAS Bolts, K-Nuts, AN Washers and other fasteners. Our stock of rod end and spherical bearings is the largest in the world, available in metric, imperial, male and female. Meeting customers' needs promptly and efficiently is the main focus of our business approach. Whether a large stock order or an urgent requirement for non-stock items – we have the solution. High grade on-site technical support is available on request, backed up by technical departments from leading bearing manufacturers. Most credits cards welcome. **Buy on-line now at our Web Shop www.autosport-bearings.co.uk for worldwide despatch.**

12.12. Oil Systems

12.12.1. Have any oil lines passing through the driver/passenger compartment protected and, if non-metallic, to be of internally or externally metal braided hydraulic pressure hose.

12.13. Fuel Systems

12.13.1. Have any fuel lines passing through the driver/passenger compartment protected and, if non-metallic, to be internally or externally metal braided hydraulic pressure hose or fuel lines complying with current FIA specifications. They may only be joined by screwed sealing joints.

12.13.2. If fitted with fuel fillers in a closed boot, or under closure, have collector/spill trays incorporated to drain outside the vehicle.

12.13.3. Use pump fuel [see definition Section P] except where permitted otherwise under SRs, Formula Rules, Championship Regulations or specifically by the MSA.

12.13.4. If using LPG, the entire system must conform with Construction and Use regulations and LPG Industry Technical Association Code of Practice No. 11.

12.13.5. If using non-pump fuel have a 3 inch diameter 'Day-Glo' orange disc affixed immediately adjacent to the Competition Numbers on both sides.

12.14. Electrical Systems

12.14.1. Have any wet batteries in driver/passenger compartment enclosed in a securely located leak-proof container.

12.14.2. Have batteries duly protected to exclude leakage of acid and to protect terminals from short circuiting and producing sparks.

12.14.3. With the exception of racing cars be equipped with battery, generator, self-starter, side, tail, and brake lights. All this equipment to be in normal working order. Exceptionally when taking part in an event held totally off the public highway, need not comply with DoT Statutory Requirements regarding lighting or horn.

12.14.4. With the exception of racing cars, or cars of periods A to C, have headlights in normal working order with glasses of minimum 182.5sq.cm *unless SRs permit their removal.*

12.14.5. Have the battery earth lead, if not readily distinguishable, identified by a yellow marking.

12.14.6. If required to have a self-starter, be able to demonstrate during the competition that it is capable of starting the engine.

12.14.7. Be fitted with suppressors as required by the Wireless Telegraphy Regulations.

12.15. Weight/Ballast

12.15.1. If subject to a minimum weight, that must be the weight of the vehicle in the condition in which it crosses the finishing line (excluding driver and passenger), or at any time during the competition and/or practice

(except for certain classes or formulae which include the driver in the total weight).

12.16. Exhausts

12.16.1. Have the exhaust system isolated from the driver/passenger compartment (e.g. beneath the floor or secured in casings of solid material).

12.16.2. Have no part of the exhaust system protruding to the rear of the bodywork more than 15cm.

12.16.3. If Racing Car with rear aerofoils, not have any exhaust pipes extending rearwards beyond the aerofoil.

12.16.4. If Racing Car without aerofoils, not have exhaust pipes extending more than 60cm beyond the rear wheel axis.

12.16.5. If Rear Engined Single Seater Racing Car, have the exhaust outlet between 4cm and 60cm from the ground.

12.16.6. Have all exhaust outlets terminating behind the mid-point of the wheelbase of the vehicle and outside the bodywork periphery in plan view. Side exhausts not to protrude more than 4cm. Cars of periods A to E are exempt from these requirements.

12.16.7. Exhaust catalytic converters may be specified for certain disciplines or formulae. Competitors are reminded of their obligation to maintain such equipment on a vehicle used on the highway where government legislation requires it.

12.17. Silencing

The reason for Silencing (SOUND CONTROL) is to reduce environmental impact and to keep Motor Sport running. Environmental Protection legislation has increased the pressure on activities generating noise and Local Authorities have the power to suppress any noise source deemed to be causing a nuisance. Our system of control is acceptable to most Environmental Bodies and must be considered as part of eligibility to Compete in events.

12.17.1. All competing vehicles are subject to mandatory silencing, unless a specific waiver for that Class, or Formula is granted. Where specified as mandatory, a silencer must be used, irrespective of the exhaust sound generated without it.

12.17.2. Vehicles which comply with the Technical Regulations of FIA Formulae and Championships set out in the current FIA Yearbook and other FIA approved Championships, Series and Cups which are participating in races for such Formulae, Championships, Series and Cups at meetings which have been entered on the FIA International Calendar are exempt from MSA sound test requirements but must comply with the sound test requirements set out in the appropriate Formulae, Championship, Series or Cup Regulations.

The following table gives alternative distance readings. (Noise measured in dB(A).)				
	0.5m	2.0m	8.0m	
Section 'A'	105	93	81	CAR RACE (SALOON AND SPORTS CARS) MAXIMUM AT $\frac{3}{4}$ MAXIMUM RPM
Section 'B'	108	96	84	CAR RACE (SINGLE SEATER AND SPORTS RACING CARS) MAXIMUM AT $\frac{3}{4}$ MAXIMUM RPM
Section 'C'	100	88	76	STAGE RALLY, AUTOTEST, TRIALS, CCV MAXIMUM AT 4,500 RPM
Section 'D'	98	86	74	ROAD RALLY MAXIMUM AT $\frac{2}{3}$ MAXIMUM RPM
Section 'E'	100	88	76	ORV MAXIMUM AT $\frac{2}{3}$ MAXIMUM RPM
Section 'F'	108	96	84	AUTOCROSS AND RALLYCROSS MAXIMUM AT $\frac{3}{4}$ MAXIMUM RPM
Section 'G'				HILLCLIMB AND SPRINT MAXIMUM AT $\frac{2}{3}$ MAXIMUM RPM – RACING AND SPORTS LIBRE CARS AND CARS COMPLYING WITH L 12 AND L 13 ALL OTHER CATEGORIES
	110	98	86	
	108	96	84	

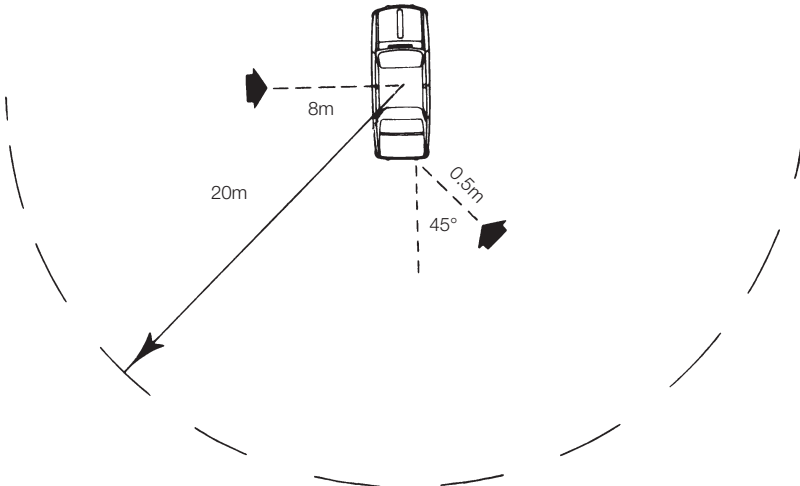

12.17.3. Silencing is not mandatory for the following categories of vehicle but is strongly recommended, and may be made mandatory in the SRs at the request of the Circuit/Venue owners:

- All cars of periods A to D. (This does not include events any part of which takes place on the Public Highway where national laws will apply.)
- Formula 1 and other single seater racing cars of periods E and F
- Drag race vehicles.
- BOSS championship cars.

12.17.4. For British Formula Three, British GT and British Touring Car Championships the sound test shall be conducted as set out within these regulations with the engine

running at $\frac{3}{4}$ maximum speed, the sound level meter at a height of 0.5 metres above the ground (+ or - 0.1 metre) located at 45° to and 0.5 metres distant from the exhaust with a maximum permitted sound level of 118dB(A).

Special regulations apply to ASCAR, only when racing on high speed oval circuits.

12.17.5. Temporary Silencers, by-pass pipes or the inclusion of temporary parts to achieve silencing requirements are prohibited. Officials may refuse to carry out Sound Checks on vehicles utilising temporary parts in exhaust systems. Organisers are empowered to exclude in such situations.

12.17.6. Sound levels may be reduced following changes in EU Regulations.

12.17.7. Circuit/venue owners/organisers may impose additional restrictions in SRs.

12.17.8. Sound Test Requirements

Measurements will be made at 0.5m from the end of the exhaust pipe with the microphone at exhaust outlet level at an angle of 45° with the exhaust outlet. Where more than one exhaust outlet is present, the test will be repeated for each exhaust and the highest reading will be used. In circumstances where the exhaust outlet is not immediately accessible, the test may be conducted at 2.0m from the centre line of the vehicle at 90° to the centre line of the vehicle, with the microphone 1.2m above the ground. Measurements should be made outdoors with no large reflecting objects (e.g. walls etc.) within 3.0m (in the 0.5m test) or within 10.0m (in the 2.0m test). Background sound levels should be at least 10dB(A) below the measured level.

With distances from 2.0m to 8.0m it is necessary that there be a minimum of 20.0m radius open flat space around the vehicle.

Where possible measurements should be taken as close as possible to the vehicle, at the defined distances, to avoid background noise.

Generally it is impracticable to take measurements over 8.0m as the background noises create problems with accurate and steady readings.

Cars of periods A to D falling within Sections C and D should run engines at two thirds maximum RPM.

The 8m location of the microphone, for practical purposes, can be considered to be 7m from saloon car bodywork. This measurement can be made from either side of the car. The highest reading registered being the one needing to comply with the maximum noise requirements.

12.17.9. Sound testing should be carried out BEFORE taking part in any competition. The time and location of sound testing should be advised to competitors prior to the event.

12.17.10. It is stressed that all participants in motor sport, competitors, officials, marshals, etc., should be aware of, and protect themselves from, noise.

12.18. Safety

All vehicles must comply with Safety Regulations as itemised under their Specific Technical Regulations and as detailed under the section headed Safety Criteria [Section Q].

12.19. Miscellaneous

12.19.1. Be of sound construction and mechanical condition and be well maintained.

12.19.2. Have positive fastenings for all doors and all hinged or detachable parts of the bodywork.

12.19.3. Have no temporary parts incorporated in their construction.

12.19.4. Not necessarily be equipped with seat belts, speedometer, spare wheel or bumpers if the event is held on private property *unless specified to the contrary by SRs*. Any exposed sharp ends of bumpers etc., must be protected.

12.19.5. Be prohibited from carrying cameras/videos unless authorised by the Chief Scrutineer and Event Organiser.

12.19.6. Not be a vehicle of commercial type, such as a van/pick-up which was initially intended solely for commercial or goods carrying, *unless permitted by SRs*.

12.19.7. Have a minimum distance of 183cm (72in) between the centre lines of the foremost front and rearmost rear substantial load-carrying wheels, unless complying with an Approved Formula.

12.19.8. Except for racing cars, be fitted with a windscreen. If plastic windscreen, sidescreens or rear windows are fitted the thickness must not be less than 4mm. Sports cars supplied as standard with plastic sidescreens may retain them in their original thickness.

12.19.9. Not have skirts, bridging devices or any form of aerodynamic device between the chassis and the ground/track. Any specific part of the car influencing its aerodynamic performance must:

- (i) comply with rules relating to coachwork.
- (ii) be rigidly secured to the entirely sprung part of the vehicle.
- (iii) remain immobile in relation to the vehicle.

12.19.10. Under no circumstance can any part of the bodywork, or of the suspended part of the car, be below a horizontal plane passing 4cm above the ground, the car being in normal racing trim with the driver aboard. A gauge of 4cm may be used by Scrutineers before or after races or practice to check the ground clearance.

12.19.11. Not carry or pass any liquids in or through any tubes comprising part of the chassis structure, or safety roll-over bar.